

## U3 SL-200/9 POMPĂ CENTRIFUGALĂ MULTIETAJATĂ VERTICALĂ

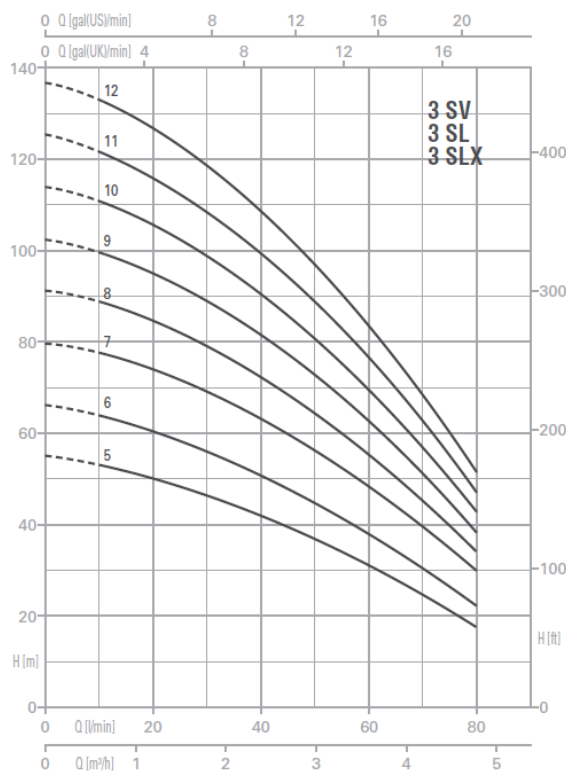

Putere absorbită P1:	1,7 kW
Putere P2:	1,5 kW
Alimentare:	230 V (50 Hz)
Înălțime de refulare max.:	103 m
Debit max.:	4800 l/h
Diametru de aspirație:	1"1/4G
Diametru de refulare:	1"1/4G
Numar de etaje	9



Debit Q (m <sup>3</sup> /h – l/min)						
0	0.6	1.2	1.8	2.4	3.6	4.8
0	10	20	30	40	60	80
Înălțime de refulare H (m)						
103	99.9	95.4	88.8	81.4	62.7	38.6

Temperatura maximă lichid:	110 °C
Carcasă pompă:	fonta
Suport motor:	fonta
Rotor pompă:	inox AISI 304
Etanșare mecanică:	grafit – carbură de siliciu
Etanșare corp pompa:	EPDM
Clasă de izolație:	F
Clasă de protecție:	IP44
Protecție termică:	Da

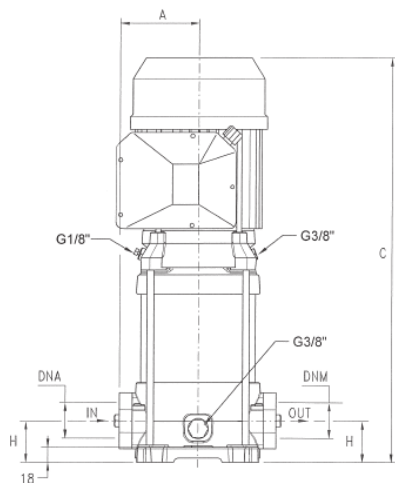
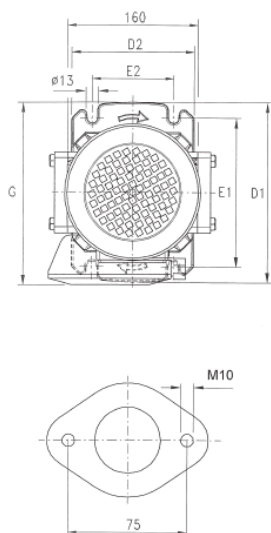

ULTRA 3SL / SLX	DIMENSIONS (mm)								Kg		DNA	DNM
	A	C	D1	D2	E1	E2	G	H	SL	SLX		
U 3SL/SLX-100/5	98	429	220	150	180	100	228	50	20,2	18,8	1"1/4G	1"1/4G
U 3SL/SLX-120/6	98	453	220	150	180	100	228	50	21	19,5		
U 3SL/SLX-150/7	98	507	220	150	180	100	228	50	24,5	23,1		
U 3SL/SLX-180/8	98	531	220	150	180	100	228	50	25,7	24,3		
U 3SL/SLX-200/9	98	555	220	150	180	100	228	50	28	26,5		
U 3SL/SLX-250/10	98	579	220	150	180	100	228	50	28,9	27,4		
U 3SL/SLX-280/11	98	M 648	220	150	180	100	M 236	50	30,4	29		
		T 603					T 228					
U 3SL/SLX-300/12	98	M 672	220	150	180	100	M 236	50	31,7	30,3		
		T 627					T 228					